

INITIAL DESIGN OF TLP FOR OFFSHORE WIND FARM

Koji Suzuki¹, Hiroshi Yamaguchi², Masayuki Akase¹, Akihiko Imakita¹, Takeshi Ishihara³,

Yukinari Fukumoto⁴, Takumi Oyama⁵

¹Mitsui Engineering and Shipbuilding Co., Ltd, 3-16, Nihonbashi 1-chome, Chuo-ku, Tokyo 103-0027, Japan

²Akishima Laboratories (Mitsui Zosen) Inc., 1-50, Tsutsujigaoka 1-chome, Akishima, Tokyo 196-0012, Japan

³The University of Tokyo, 7-3-1, Hongo, Bunkyo-ku, Tokyo, 113-8656, Japan

⁴Tokyo Electric Power Company, 4-1, Egasaki-cho, Tsurumi-ku, Yokohama, 230-8510, Japan

⁵Shimizu Corporation, 3-4-17 Etchujima, Koto-ku, Tokyo 135-8530 Japan

Conceptual design of TLP (Tension Leg Platform) for wind turbine was carried out in consideration of mooring force and easy maintenance. Numerical analyses were performed on dynamic response and tension deviation of leg in waves, natural frequency of vibration, and dynamic response to seismic force. As a result, it is found that the proposed TLP has excellent characteristic features in dynamic response as a floating foundation for a wind turbine. It is also found that it keeps sufficient safety factor to extreme environmental conditions including earthquake, and is free from resonance with a wind turbine system.

Keywords: offshore wind farm, TLP, dynamic response, vibration, seismic load

INTRODUCTION

Wind turbine (WT) is one of the most desirable and promising green energy generators in the field of renewable energy production. In Europe, offshore wind farms using fixed foundation are widely in operation. On the contrary, in Japan the depth of coastal sea is relatively deep. Therefore floating foundations have been studied as a support structure for a WT [1]. Among various types of floating foundation for offshore wind farm, TLP (Tension Leg Platform) is regarded as one of the leading candidates [2] [3].

In general, TLP has characteristic feature that its dynamic response to environmental forces is small and thus almost the same WT as on land can be installed on the TLP. However, as the TLP has tendons fixed on the sea bottom, it may be subject to seismic load.

In this paper, particulars of a TLP for offshore wind farm are proposed and its dynamic responses in winds and waves were investigated. In addition to those, natural frequency analysis was carried out to confirm non resonance with the WT. Dynamic responses to seismic design loads were also studied for confirmation of its safety factor.

DESIGN CONDITIONS AND REQUIREMENTS FOR TLP WITH WT

TLP is a floating structure moored by tendons connecting the structure and anchors on sea bottom. Its position is kept in terms of tendon tension created by excessive buoyancy of the floating structure. In this study, the initial design of a TLP for a 2.4MW class WT

was carried out. In order to determine principal particulars of a structure and a mooring system, the following conditions and requirements are considered.

Environmental conditions

The installation site is assumed to be off the Japanese coast. Environmental conditions considered in this study are shown in Table 1. These values are adopted from past study [4].

Table 1. Environmental conditions

Condition	Significant Wave Height (m)	Wave period (s)	Wind Speed (m/s)	Current Speed (m/s)	Water depth (m)
Rated	3.9	7.4	12.5	1.85	100
Cut-out	7.1	9.8	25.0		
Extreme	12.0	13.4	50.0		

Requirements

Following requirements for installed WT are considered [1] [4].

- Rated condition: 5 degrees or less for average inclination
- Cut-out condition: 0.2G or less for maximum acceleration of a nacelle
- Extreme condition: Blades must not touch the wave surface

To ensure functions of a TLP system even under extreme condition, the following requirements are considered.

- Under tendon tension, sufficient safety margins (safety factor 3.0) to breaking stress should always be kept.
- Tendon tension should always be kept in positive (Should not slack).

PARTICULARS OF FLOATING STRUCTURE AND MOORING SYSTEM

Floating structure

Considering the abovementioned conditions, principal dimensions of the structure and tendons are determined as shown in Fig.1. Principal particulars are given in Table 2. This TLP has the following features.

- It has a center column, three corner columns and horizontal pontoons connecting the center column and corner columns.
- Top of the columns is above water surface, and each tendon is moored on the top of it to provide easy maintenance (anchorage, tension adjustment, de-anchorage).
- Corner columns contribute to the stability on sea transportation, installation, and removal (at non mooring condition).
- pontoons keep enough draft in order to avoid exposure to wave surface under extreme condition, which causes excessive impact load.
- Two tendons are arranged in each corner in order to secure redundancy and to enable replacement of the tendons.

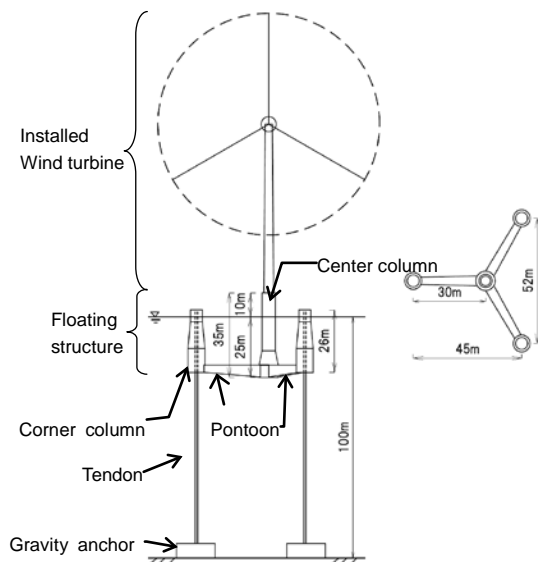

Fig. 1. General arrangement of TLP.

Table 2. Principal dimensions of proposed floating structure

Installed wind turbine (WT)	Hub height (From Center column top)	70 m
	Rotor diameter	92 m
Floating structure	Distance between Center column and Corner column	30 m
	Depth	35 m
	Draft	25 m
Initial condition	Displacement	4100 ton
	Ballast (sea water)	840 ton
	Initial pretension (total)	13740 kN

Mooring system

Parallel Wire Strand (PWS) cables protected by polyethylene sheath are adopted for the tendons. PWS cables have been developed and are widely used as tensile members of suspension bridges. It is highly flexible and superior in corrosion and abrasion resistance. The specification of the tendon and initial tension are determined to satisfy the requirements, considering the overturning moment caused by wave, wind, current, and tide. Principal dimensions of the tendon are shown in Table.3.

Table 3. Principal dimensions of tendon

Diameter of wire	7mm
Breaking stress	1570N/mm ²
Number of wires	241
Sectional area	9270mm ²

DYNAMIC RESPONSE OF TLP IN WAVES, WINDS AND CURRENT

The coordinate system and the modes of motion are shown in Fig.2. The origin of this system is taken as the center of gravity. Surge, sway and heave represent linear motion along the x, y and z axes respectively. Roll, pitch and yaw are rotation about the x, y and z axes respectively.

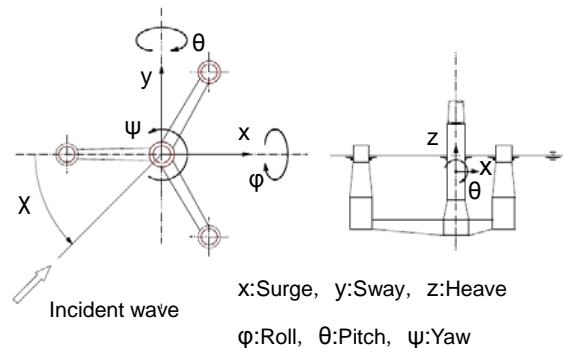

Fig. 2. Coordinate system and modes of motion

Dynamic response in waves

The Dynamic responses of TLP in waves were analyzed in the frequency domain and also in the time domain. The hydrodynamic forces and wave exciting forces were calculated by means of 3D Green Function's method [5]. The response amplitude operators (RAOs) were obtained considering the drag forces acting on the columns. The maximum expected values were calculated by using RAO and wave power spectrum. Results are shown in Table 4. As shown in the table, responses of heave and pitch are very small. Furthermore, in cut-out condition, horizontal acceleration value at nacelle (0.14G) satisfies the required value (0.2G).

Table 4. Maximum expected values of responses in wave ($\chi=180\text{deg}$)

Condition	Surge (m)	Heave (m)	Pitch (deg)	Tendon tension (kN)	Horizontal acceleration at nacelle (m/s^2)
Rated condition	0.99	0.01	0.03	290	0.69 (0.07G)
Cut-out condition	3.35	0.02	0.05	530	1.36 (0.14G)
Extreme condition	9.34	0.02	0.06	743	2.25 (0.23G)

In order to examine the effect of geometric non-linearity of the tendons, time domain simulations were conducted. Fig.3 shows the example of the simulations under extreme condition. The maximum total tendon tension is about 3000kN including initial pretension, therefore the effect of non-linearity on the tendon tension is not significant in this case.

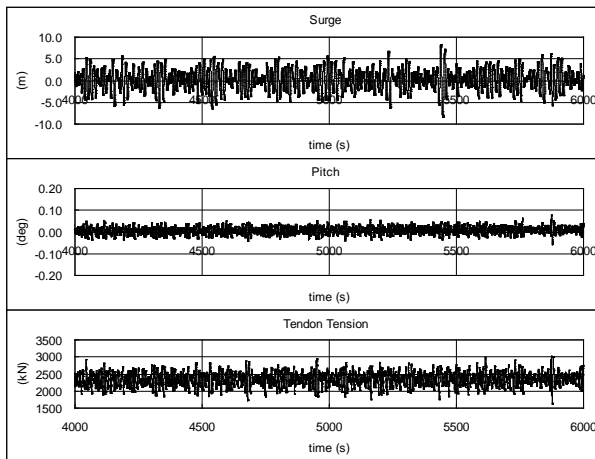

Fig. 3. Time history of surge, pitch motion and tendon tension in wave (extreme condition).

Tendon tension under combined external forces

Maximum and minimum tendon tensions in wave, wind and current were confirmed. The wind and current forces are assumed as steady forces. As shown in Table 5, the tension force is kept positive, and safety factor 3.0 to breaking strength is also kept even under

extreme condition.

As a result, it is confirmed that all the design requirements, such as acceleration at nacelle, tendon tension and etc., are satisfied.

Table 5. Maximum and minimum values of tendon tension in extreme condition (per one tendon)

Load type	Tendon load at top connector
Initial pretension	2290kN
Tension variation due to wind and current forces	1334 kN ~ -1020 kN
Wave induced tension variation	743 kN ~ -743 kN
Total tension	4367 kN ~ 527 kN

VIBRATION ANALYSIS

FE model was created to find natural frequency of TLP with WT systems. The structure is modeled with beams, and added water mass and WT mass is included in the FE model. Tendons are modeled by springs. An example of the results is shown in Fig.4 and Eigen frequencies are given as per Table 6. It shows that the resonance with the natural frequency of TLP is comfortably avoided with exciting forces of 0.25Hz (rotational frequency) and 0.75Hz (blade frequency).

4th, 5th mode 6th mode 9th, 10th mode

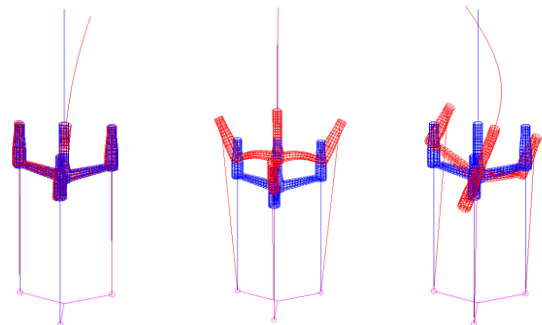

Fig.4 Vibration modes

Table 6. Eigen frequency

Order	Vibration Mode	Eigen Freq.	Period
1 st , 2 nd	Floating structure/Surge	0.0273 Hz	36.6 s
3 rd	Floating structure/ Rotation	0.0358 Hz	27.9 s
4 th , 5 th	Tower/Bending	0.275 Hz	3.64 s
6 th	Floating structure/Heave	0.638 Hz	1.57 s
9 th , 10 th	Floating structure/Pitch & Tower/Bending	1.09 Hz	0.92 s

Dynamic response to seismic load

Past researches showed the occurrence of large force amplitude when TLP was subjected to seismic load [6]. Therefore dynamic response of the proposed TLP is investigated by a time domain response analysis to design against typical seismic loads experienced at El Centro, Taft, Tohoku, and Hachinohe. The design loads used in the analysis are derived out of the past researches. Examples of the seismic acceleration waves are shown in Fig. 5. Correction of factor was made to represent rare seismic load in which maximum amplitude of velocity should be 25 cm/s.

Examples of calculated displacement time history are shown in Fig. 6. Observation points are at the top of corner column and nacelle. The calculated tension variations are shown in Table 7 after the correction. It is found that the tension is kept well under the tendon strength and there is no slack during earthquake.

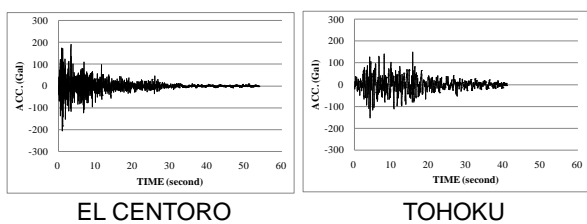

Fig.5 Seismic acceleration waves
<Direction: Up-Down>

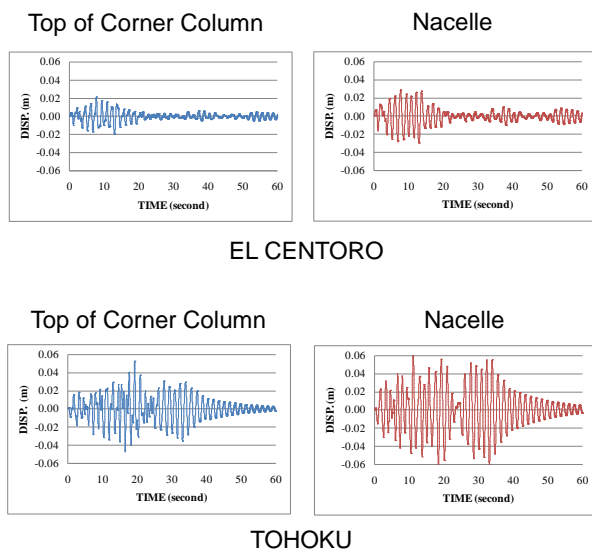

Fig.6 Responses of vertical displacement

Table 7. Tendon tension in seismic condition
<per one tendon>

Seismic Waves	Pretension (kN)	Tension Variation(kN)	Total Tension(kN)
El Centro	2 290	-820~907	1470~3197
Taft		-1630~2077	660~4367
Hachinohe		-1747~2070	543~4360
Tohoku		-1797~2020	493~4310

CONCLUSIONS

In this paper the TLP for a 2.4MW offshore WT is proposed and the dimension of the structure is determined under the assumed design conditions. As a result, the following conclusions are obtained.

- (1) Dynamic response in wave was analyzed based on the particulars determined in the conceptual design. As a result, it is found that natural periods of heave and pitch are rather short and amplitudes of motions are very small. This finding indicates that the WT used on land can be installed on the TLP without major modification.
- (2) Maximum tendon tension calculated in wind, current and waves is well under the tendon breaking strength with sufficient safety factor. Minimum tendon tension is kept in positive, which means no slack occurs even under extreme condition.
- (3) Vibration analysis was performed by using FE model of the TLP with the WT system. It is confirmed that the TLP does not have resonance with the WT system.
- (4) Time domain response analysis to seismic load was carried out to confirm behavior of the TLP during earthquake. Tension in tendon has been found to be within design value and it has also been confirmed that the proposed TLP keeps sufficient safety factor during earthquake.

References

- [1] Y. Fukumoto et al., "Observation of offshore wind climate and development of offshore wind power generation systems", *Annual journal of civil engineering in the ocean, JSCE (in Japanese)*. **24**, 2008, pp.1-6.
- [2] E.N. Wayman et al, "Coupled dynamic modeling of floating wind turbine systems", *NREL/CP-500-39481*., 2006.
- [3] K. Suzuki, H. Yamaguchi, M. Akase, S. Nakada, A. Imakita, "Development of a TLP type floating structure for offshore wind farms", *Mitsui zosen technical review (in Japanese)*. **198**, 2009, pp.31-38.
- [4] K. Anno et al., "Characteristics of truss spar and semi-submergible floating structures for offshore wind power generation", *Annual journal of civil engineering in the ocean, JSCE (in Japanese)*. **24**, 2008, pp.123-128.
- [5] M. Kobayashi et al., "Dynamic Response Analysis of Marine & Offshore Structures (DREAMS)", *Mitsui zosen technical review (in Japanese)*. **126**, 1985, pp.1-10.
- [6] T. Kawanishi et al., "Response of tension leg platform under earthquake", *Journal of the Kansai Society of Naval Architects, KSN AJ (in Japanese)*. **182**, 1981, pp.83-90.